

# SAMPLE AUDIO SETUP SCENARIOS

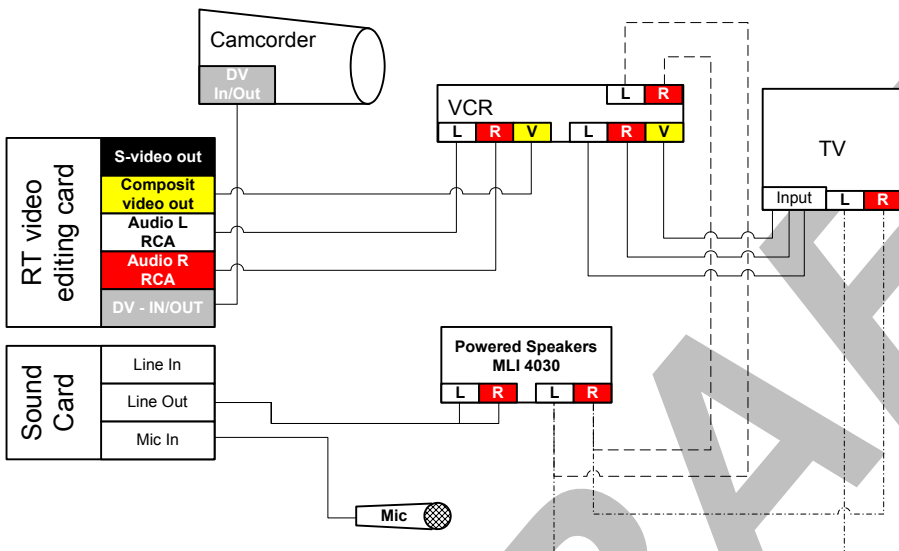

In this case the sound control is from either the audio out of the TV or the VCR (if any of them has it)  
The monitor audio out can be connected back to the sound card and mixed with the multimedia mixer - this is an option with one-input powered speakers

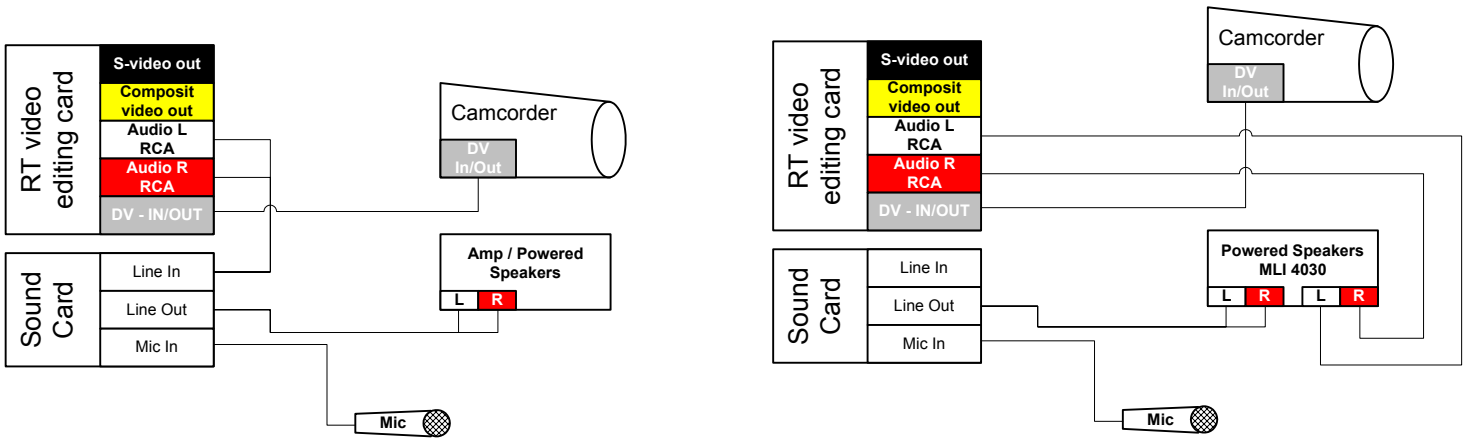
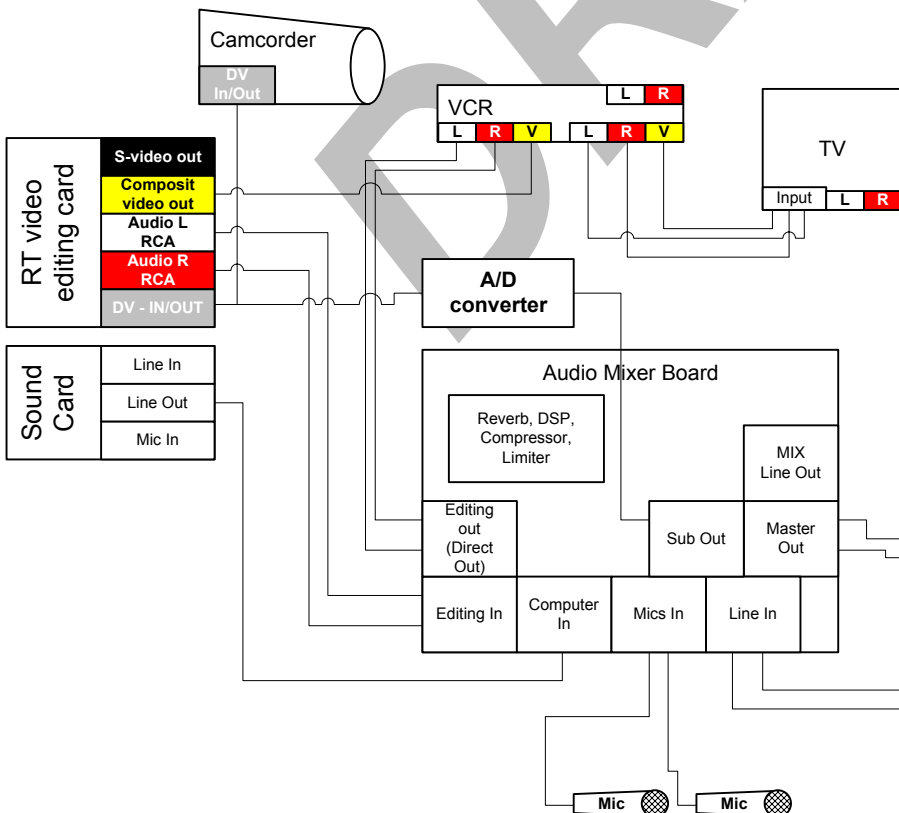

This is only a sample setup, since the variety of options mainly depends on the needs and the capability of sound equipment

It is recommended to send mic signal into the system through DV IN using the A/D converter (eg: Canopus ADVC100 or ADVC 50; Canopus Storm2). This method allows us to capture audio with 48kHz. The quality and capabilities of a general sound card will not meet or needs for high quality video production.